

PROFIL INTERLOKING , DECUPAJ SEGMENT, SUPRAFATA RUGOASA

Țigla solzi cu suprafață profilată.

- Accentuează structura profilată
- Colorare diferențiată
- Posibilități unice de combinare și realizare
- Se îmbină armonios în peisajele existente de acoperiș

DATE TEHNICE

Mărime (aprox.)	205 x 400 x 21 mm
Lățime de acoperire max. (aprox)	180 mm
Dist. min. șipci (aprox.)	270 mm
Lungime acoperire medie aprox.	285 mm
Dist. max. șipci (aprox.)	300 mm
Necesar mediu de țigle (aprox.)	19.2 buc/m ²
Greutate/unitate de produs - buc. (aprox.)	2.52 Kg/buc
greutate per m ² (aprox.)	48 kg/m ²
greutate per pallet (aprox.)	803 Kg
Buc. per mini-pack	6 bucata
Buc per palet	324 bucata





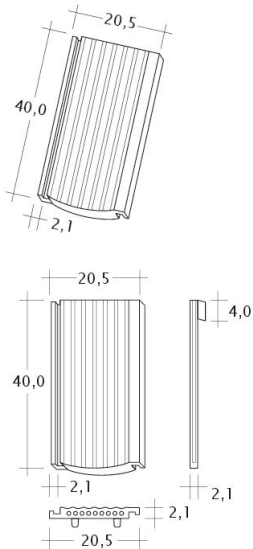

Desen tehnic produs PROFIL Strangfalz-gewellt-1-1

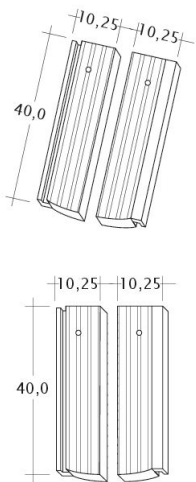

Desen tehnic produs PROFIL Strangfalz-gewellt-1-2



Ort angausbildung der Einfachdeckung mit Flächenlüfter mit Strangglasziegel.

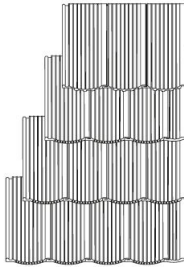

Desen tehnic produs PROFIL OGAusbildung-Laengshalber

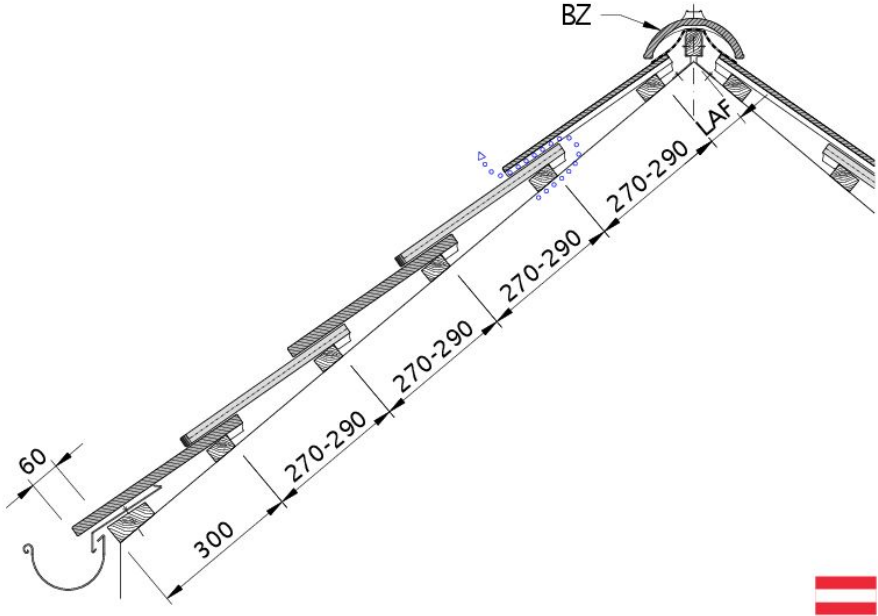

Desen tehnic produs PROFIL DQF DQF-AT



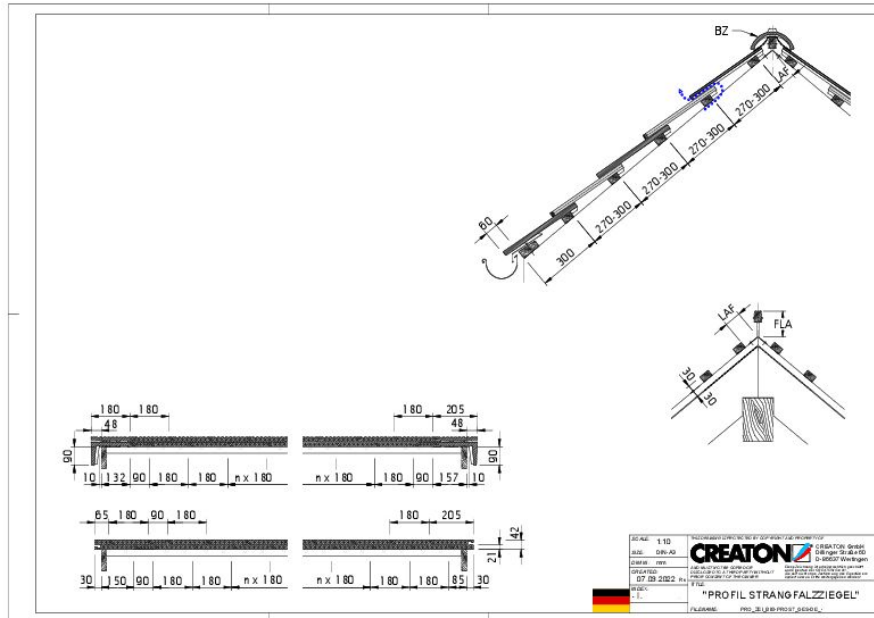

Drawing PROFIL general view GES-DE

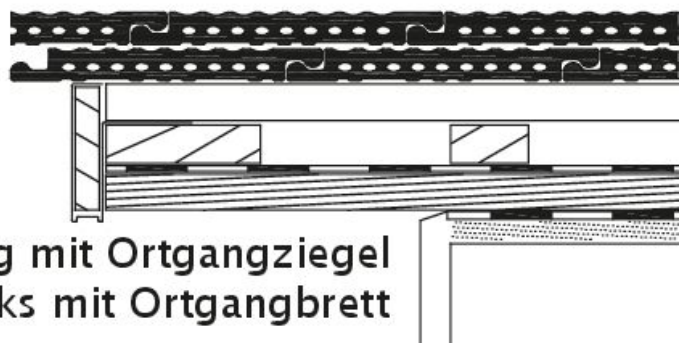
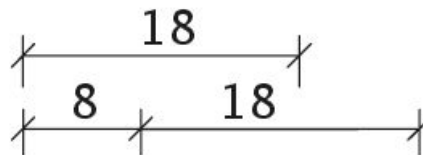

Ortgangausbildung mit Ortgangziegel links mit Ortgangbrett

Desen tehnic produs PROFIL Țiglă laterală stânga OBL



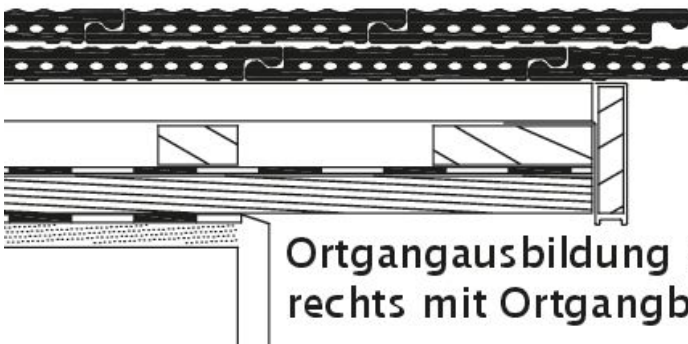

**Ortgangausbildung mit Ortgangziegel
rechts mit Ortgangbrett**

Desen tehnic produs PROFIL Țiglă laterală dreapta OBR

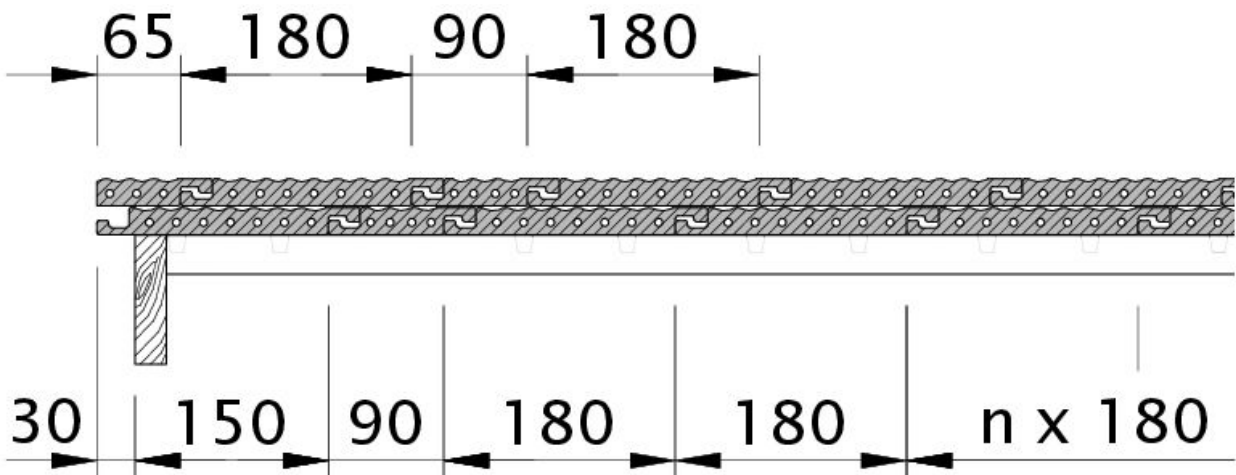

Desen tehnic produs PROFIL Țiglă laterală stânga cu proeminență ODL



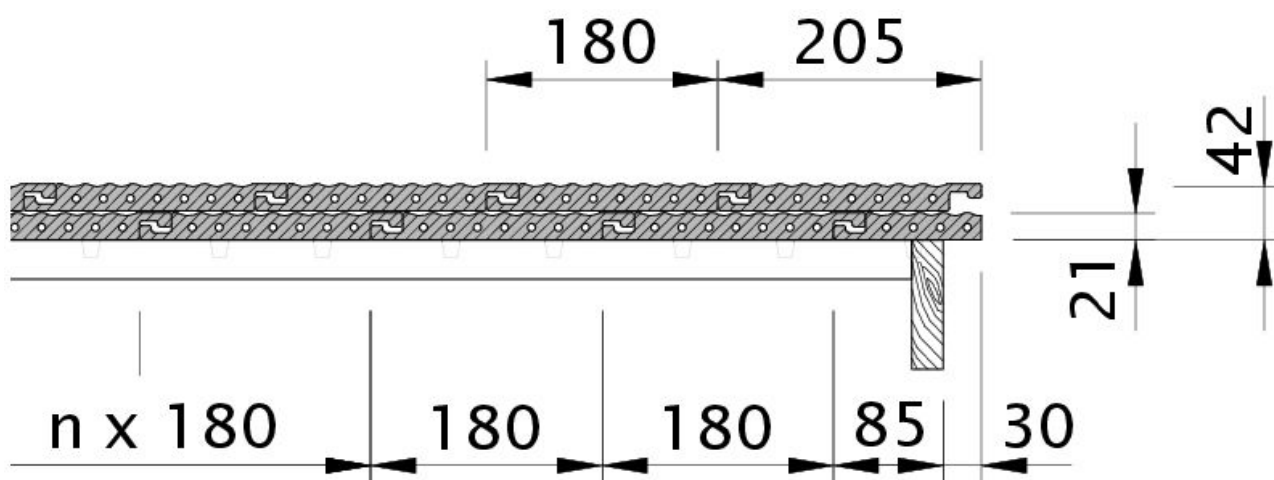

Desen tehnic produs PROFIL Țiglă laterală dreapta cu proeminență dublă OFR

